

Article

# Design and implementation of novel 6G cellular communication architecture using 3D modelling in real environments

Mahmood A. Al-Shareeda\*, Muhammad Majid Al-Phryggy, Ali Abd Khadim Al-Kashani,  
Haider Adnan Al-Jaber, Jabbar Deyaa Al-Moussawi

Communication Engineering, Iraq University College, Basra 61001, Iraq

\* **Corresponding author:** Mahmood A. Al-Shareeda, [m.alshareeda@iuc.edu.iq](mailto:m.alshareeda@iuc.edu.iq)

## CITATION

Al-Shareeda MA, Al-Phryggy MM, Al-Kashani AAK, et al. Design novel 6G cellular communication architecture using 3D Modelling App. *Computer and Telecommunication Engineering*. 2024; 2(2): 2668. <https://doi.org/10.54517/cte.v2i2.2668>

## ARTICLE INFO

Received: 17 February 2024

Accepted: 22 March 2024

Available online: 3 April 2024

## COPYRIGHT



Copyright © 2024 by author(s).

*Computer and Telecommunication*

*Engineering* is published by Asia

Pacific Academy of Science Pte. Ltd.

This work is licensed under the

Creative Commons Attribution (CC BY) license.

<https://creativecommons.org/licenses/by/4.0/>

**Abstract:** Academics and businesses alike are presently fixated on the Sixth Generation (6G) network, which is seen as the telecom industry's next major game-changer. The 6G architecture has not been finalized and is not yet being used in commercial settings. Research and development for 6G is still in its early stages. Several important features and technologies have surfaced as possible 6G system underpinnings, while development is still in its early phases. To facilitate the next generation of 3D modeling applications, this article suggests a new 6G cellular communication architecture. Aware of 6G's revolutionary potential, we investigate its fundamental features to build a collaborative, real-time 3D modeling environment with unmatched capabilities. The goal of this project is to design the architecture for the next generation of communications systems. This will incorporate elements from two existing designs: the decoupled RAN design, which improves security and smooth data sorting, and the high-level design, which incorporates numerous protocols inside the antenna for stringent protection. Lastly, we delve into the possible sector-specific disruptions caused by this design and examine its wider implications for the future of 3D modeling. We hope that by introducing this new 6G architecture, we may inspire more study and development towards a day when 6G technology completely changes the game when it comes to 3D modeling.

**Keywords:** 6G; 3D modeling App; 6G architecture; future work

## 1. Introduction

There is about to be a dramatic shift in the wireless communication industry. Even though 5G has only just begun to unveil its full potential, scientists and engineers are already planning for 6G, the next generation of wireless networks [1–3]. The potential for this emerging technology to revolutionize our current state of affairs is enormous since it will undoubtedly increase the limits of speed, reliability, and connectedness [4–6].

Global mobile-generated data traffic is projected to skyrocket to 5.016 Zeta Bytes (ZB) per month by 2030, from 0.062 ZB in 2020 [7], due to the anticipated 97 billion machine-type devices. On top of that, a global poll predicted that 43 megacities will have 10 million residents by 2030 [8].

Since urbanization and smart city ecosystems like smart transportation, healthcare, and buildings produce huge amounts of data from mobile devices, information and communication technology (ICT) must be both flexible and resilient. There will be an explosion of data due to new applications in fields like artificial intelligence (AI), robotics, industry 4.0, and the Internet of Everything (IoE), among many others. In this setting, cellular network infrastructure is going to play a significant role in enabling these sectors to have high bandwidth, quality of service

(QoS), and extreme data rates [9–11].

Since 5G networks have not been fully deployed globally just yet, research on their real-time performance across all use cases is limited [12–14]. However, looking at the telecom industry’s progress [15], it’s clear that every generation needs ten years to go from goal formulation to research and development to standardization to market launch. The next generation, 6G, is expected to be available to customers around 2030 if current trends continue. Due to the immaturity of the technology, academics and businesses may only have a theoretical framework for 6G networks at this point. In this book, we will explore many facets of future networks, inspired by the ongoing research on 6G networks and their technological components. A variety of sources have provided insight into the goals, needs, technologies, and use cases of 6G networks [16,17]. The main contribution of this paper is listed as follows.

- we summarise the important findings from prior studies and offer predictions about the direction of 6G network research going forward.
- we propose a new 6G Architecture using a 3D modeling App.

The rest of this paper is structured as follows. Section II provides a background of the paper. Section III shows the existing 6G architecture in terms of decoupled RAN architecture and high-level architecture. Section IV proposed the 6G architecture of this paper. Section V provides the implementation and results. Finally, the conclusion and future work are introduced in Section VI.

## 2. Background

### 2.1. Overview of generation cellular communication

As shown in **Figure 1**, we provide types of generation cellular communication. So, this section reviews and compares the types of generation cellular communication as follows.

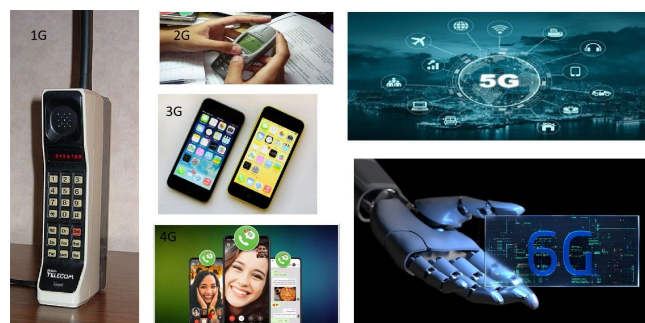

**Figure 1.** Types of generation cellular communication.

- First Generation: Its initial release was in 1980, and all of its transmissions were analog. This generation’s phones were widely utilized because they could communicate over larger distances than landline phones, had a far more accurate call sound, and were widely distributed around the world [18].
- Second Generation: With the introduction of this generation in 1990 came the shift from analog to digital communications. It was possible to connect over greater distances, have better call quality, and most notably, send 64 kbps data transfers (compared to 2.4 kbps in 1G) [19].

- Third Generation: 3G, which debuted in the year 2000 and had exceptionally strong transmission in mobile networks, was the first generation of Internet networks; subsequent generations included 2.5G, 2.75G, 2.875G, and 3G proper. Data transfer speeds and communication quality leapt ahead of previous generations. In this same instant, engineers decided to elevate communications to their pinnacle [20].
- Fourth Generation: The following generations were introduced in 2006: 3.5G, 3.75G, 3.9G/3.95G. As anticipated, both the quantity and quality of calls rose, and video calling became a reality; moreover, 4G networks provide quicker data download and upload rates than 3G. Increased network capacity enables more simultaneous connections, reduced latency for more responsive user experiences, improved signal quality and spectral efficiency through advanced antenna techniques using MIMO (Multiple Input Multiple Output) and beamforming, and theoretically speeds of up to 100 Mbit/s for high mobility communication and 1 Gbit/s for stationary users are all part of 4G [21].
- Fifth Generation: 5G networks were introduced in 2019, following 4G/4.5G, 4.5G, and 4.9G. These networks offer faster download speeds, reaching a peak of 10 Gbit/s when there is only one user on the network. 5G has more bandwidth than 4G, allowing it to connect more devices at once, improving the quality of Internet services in crowded areas [22]. Additionally, 5G has opened up new applications in the Internet of Things (IoT) and machine-to-machine domains. 5G employs an adaptive modulation and coding scheme (MCS) to maintain an exceptionally low block error rate (BLER), with an optimum” air latency” of 8 to 12 milliseconds.
- Sixth Generation: We’re going to enter the future with the sixth generation, which is set to be released in 2030 [23]. 6G is going to revolutionize mobile communication systems by outdoing its predecessors and bringing revolutionary new technologies that will change our lives, careers, and interactions in the next decades. Although 6G is still in its early phases of development, several important characteristics and technologies have surfaced that might serve as its basis.

**Table 1** shows a comparison of different technology generations.

**Table 1.** Comparison of different technology generation.

	2G	3G	4G	5G	6G
year	1990	2000	2010	2020	2030
Max DL speed (theoretical)	473.6 kbps	42 Mbps	3 Gbps	20 Gbps	1 tbps
Avg DL speed (practical)	50 kbps	8 mbps	100 Mbps	300 Mbps	1 gbps
Max UL speed (theoretical)	473.6 kbps	11.5 mbps	1.5 gbps	10 Gbps	10 Gbps
Avg UL speed (practical)	50 kbps	2 Mbps	50 Mbps	100 Mbps	1 Gbps
E2E Latency (practical)	600 ms	120 ms	30 ms	10 ms	1 ms

**Table 1.** (Continued).

	<b>2G</b>	<b>3G</b>	<b>4G</b>	<b>5G</b>	<b>6G</b>
Reliability	99%	99.9%	99.99%	99.999%	99.99999%
Connection density (devices)	N/a	N/a	$10^5/\text{km}^2$	$10^6/\text{km}^2$	$10^7/\text{km}^2$
Mobility	150 km/h	300 km/h	350 km/h	500 km/h	1000 km/h

## 2.2. Disadvantage of 5G generation

- **Limited Coverage:** 5G networks may not be available in rural areas or may have slower speeds if they are initially deployed just in densely populated urban areas. We are presently engaged in the development and execution of the necessary infrastructure for extensive deployment of 5G coverage [24].
- **Infrastructure Requirements:** Due to the increased data capacity and reduced signal range of 5G networks, a significant amount of additional infrastructure is required, including more cell towers and smaller cells. Establishing these infrastructural components can be a time-consuming and costly process.
- **Higher Costs:** Telecommunication companies will face substantial costs when they implement 5G technology. These costs encompass infrastructure upgrades, equipment installation, and spectrum purchase. A consequence of these expenses, customers may encounter higher service fees or equipment prices.
- **Limited Penetration through Obstacles:** 5G networks utilize higher frequency bands, which are susceptible to environmental variables such as buildings, trees, and rain due to their shorter wavelengths. Consequently, networks running at higher frequencies may exhibit inferior signal penetration and coverage when compared to networks operating at lower frequencies.
- **Device Compatibility:** Only smartphones and tablets equipped with integrated 5G modems are capable of utilizing 5G technology. The initial availability of affordable and widely accessible 5G devices may be limited, which could hinder the rate of adoption.
- **Potential health concerns:** Concerns have been raised by certain individuals regarding the potential long-term effects of 5G networks' utilization of higher-frequency electromagnetic radiation on their well-being. Continuous research is being conducted to ensure the safety of 5G technology, despite the consensus among scientific studies and regulatory bodies that it is indeed safe.
- **Security and Privacy:** There is a potential rise in cybersecurity risks and privacy breaches due to the proliferation of connected devices and data transmission. The necessity for strong security measures to guard against such vulnerabilities is growing in tandem with the number of interconnected devices.

## 2.3. 6G features

The following 6G features are explained:

- **Communication for 6G is THz.** Terahertz waves outperform wireless microwave-infrared data rates and bandwidths. VR/AR, HD streaming, and holographic communication could change with terahertz communication. Signal propagation, antenna design, and modulation are explored in terahertz communication.

- The 6G networks will incorporate AI/ML. AI optimizes resource allocation, network efficiency, and context-aware services. Network management, predictive maintenance, and security benefit from ML. 6G networks will match user needs with AI and ML-powered intelligent automation, autonomous decision-making, and adaptive networking [25].
- Other 6G development areas include quantum communication. Unmatched data transfer security comes from quantum key distribution. Quantum communication inhibits hackers and eavesdroppers. Quantum computing in 6G networks could enable complicated computations and simulations to improve wireless system processing.
- Global connectivity improves IoT. 6G intends to connect IoT devices safely and quickly. Billion-device 6G requires network management, energy efficiency, and device density. Intelligent transit, smart cities, industrial automation, and personalized healthcare are optimized. Sustainability and energy efficiency are important to 6G development. Growing environmental concerns require wireless network energy and carbon footprint reduction. 6G energy efficiency demands improved power control, harvesting, and network optimization. 6G integrates sustainability, technology, and responsibility [26].

## 2.4. Standard of 3GPP

6G relies heavily on 3GPP:

- Cellular network technical specifications, beginning with 2G (GSM) and continuing through the present 5G standard, are developed by the 3GPP (3rd Generation Partnership Project), the leading standardisation organisation. The development of 6G specifications was also formally committed to in December 2023 [27].
- Expanding on Past Achievements: Their track record of successfully developing intergenerational global standards sets them up for success with 6G. Because of this, devices and networks from various areas and vendors will be able to work together seamlessly.
- Participation from stakeholders around the globe in the development of 6G standards is warmly welcomed by 3GPP. As a result, 6G will be approached in a thorough and novel manner [28].

We're just getting started with 6G development, but 3GPP is leading the way, using their knowledge to influence mobile communication's future.

## 3. Existing 6G architecture

In this section, we mainly focus on these two 6G architectures called, decoupled RAN architecture [29] and high-level architecture [30]. A description of those architectures is provided as well.

### 3.1. Decoupled RAN architecture

An example of a 6G network design is a decoupled Radio Access Network (RAN), which keeps the radio unit (RU) and baseband unit (BBU) operations physically separated [29]. The design of this architecture makes it easier to establish and

administer networks, and it also accommodates future growth. The separation of RAN functions allows operators to place RUs closer to end-users for better coverage and lower latency, and to place BBUs in data centers or other central locations for better use of resources and easier control. Due to this partitioning, the network is better equipped to adjust to changing user needs and various deployment scenarios. **Figure 2** shows the description of the decoupled RAN architecture.

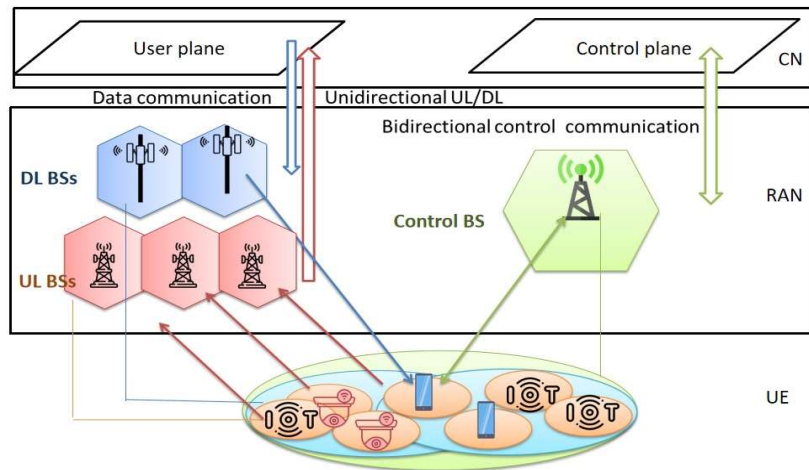

**Figure 2.** 6G-Based decoupled RAN architecture.

### 3.2. High-level architecture

The three tiers that make up a 6G network design are the control plane, the user plane, and the AI plane. By integrating storage, computation, and networking capabilities inside the user plane, hierarchical structures are eliminated in this arrangement. The user plane connects an access network to the internet in a flat manner. The control plane and AI planes, meanwhile, are virtualized and spread out to accommodate many services. With software-defined virtualization, the transport network is also virtualized and partitioned. Serverless computing allows for the modularization of essential network tasks into smaller, more manageable microservices. **Figure 3** shows the description of 6G-based high-level architecture.

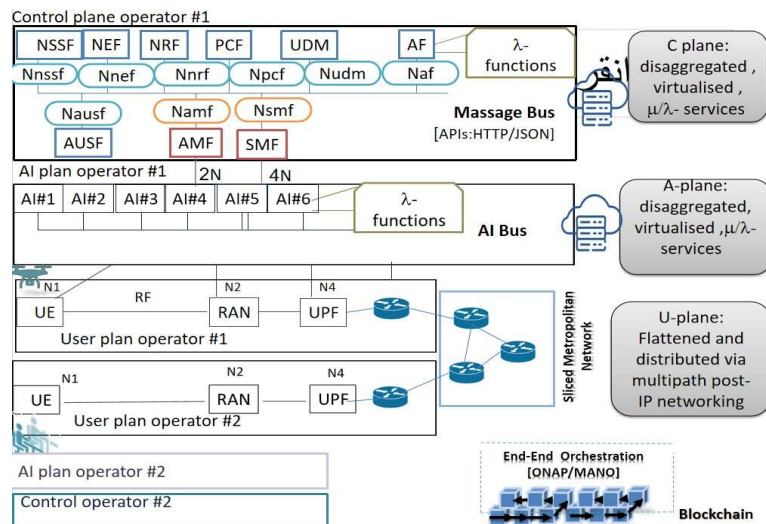

**Figure 3.** 6G-Based high-level architecture.

## 4. Proposed 6G architecture

### 4.1. Framework

Figure 4 shows the proposed 6G architecture in terms of the control plane and data plane. The phases of proposal 6G architecture are provided as follows.

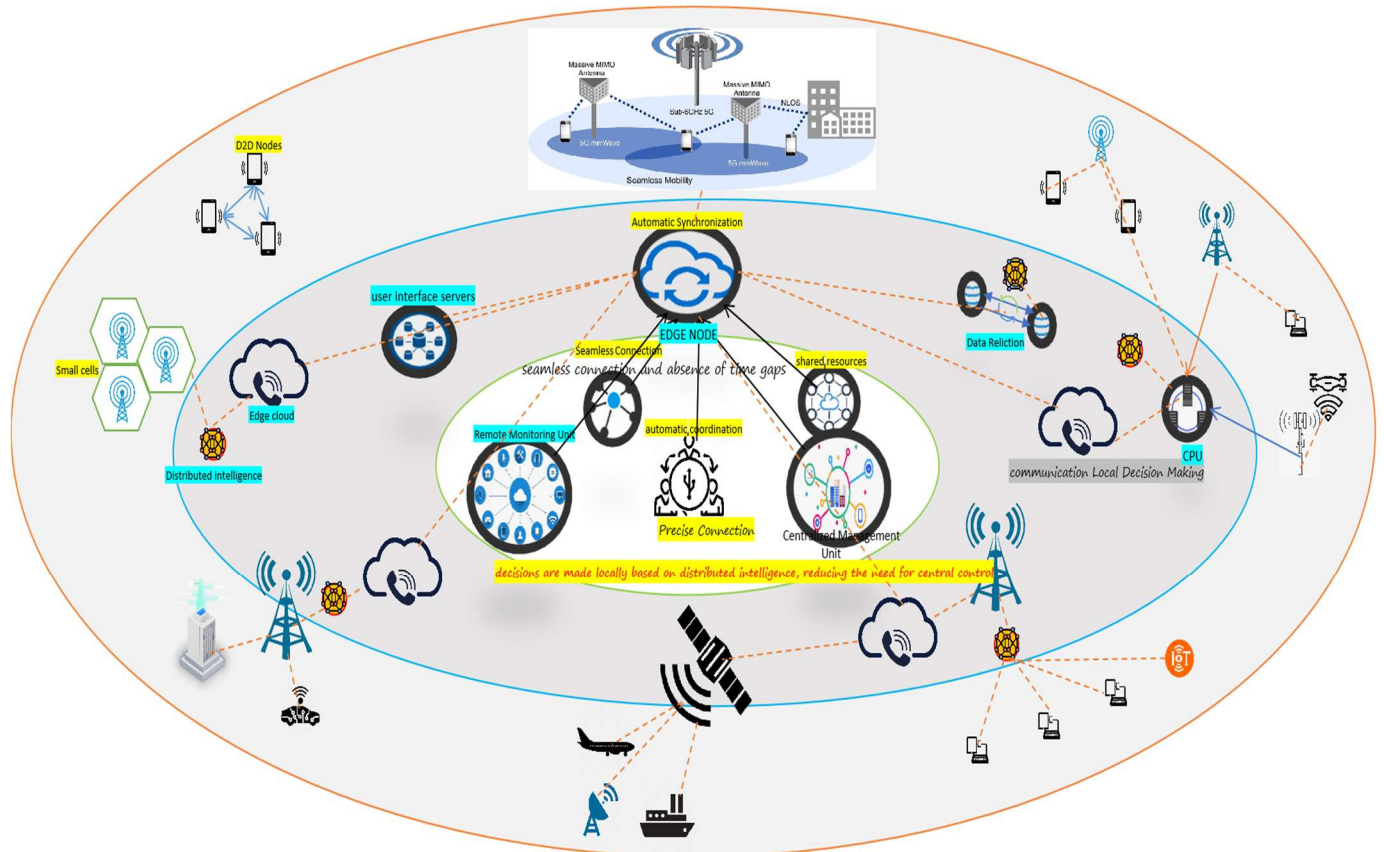

Figure 4. Proposed 6G Architecture.

### 4.2. Unified control and user plane

A unified design that incorporates both the control and user planes consolidates their respective tasks and operations into a single system. I will show you how to do it:

- **Architectural Design:** We crafted the network design such that the control plane and user plane operations can coexist on a single platform.
- **Software Development:** Make modules or components of software that can manage control plane and user plane operations simultaneously.
- **Data Flow Management:** We make sure that the unified architecture's control and user plane components can communicate with one another without any hitches.
- **Resource Allocation:** Ensure that the control plane and user plane operations are adequately provisioned with processing power, bandwidth, and other necessary resources by optimizing their allocation within the unified architecture.
- **Synchronization Mechanisms:** Facilitate coordination between the user plane and control plane through the implementation of synchronization mechanisms.
- **Testing and Validation:** Evaluate the scalability, stability, and performance of the

unified architecture through thorough testing.

- Deployment and Rollout: Once the validation process is complete, implement the unified architecture in production environments and gradually replace the old network equipment with the new one.

### 4.3. Distributed intelligence

Implement distributed intelligence across the network to enable local decision-making and resource management. Through the decentralization of power, this approach reduces administrative burdens.

- Identify Decision Points: Determine the specific areas inside the network where localized intelligence can have a significant impact on important decision-making moments.
- Develop Intelligent Agents: Develop intelligent modules or agents capable of evaluating the present state of a network, collecting relevant data, and autonomously making decisions based on provided algorithms or machine learning models.
- Connect to DIS: Integrate all of the intelligent agents into a central DIS (Distributed Intelligence System).
- Define Communication Protocols: Communication mechanisms and interfaces that let intelligent agents interact with the DIS.
- Deploy Intelligent Agents: Deploy intelligent agents at designated decision points inside the network infrastructure.
- Enable Local Decision-Making: Empower intelligent agents to autonomously determine activities based on operational requirements and local network circumstances.
- Monitor and Adapt: Ensure continuous monitoring of the decision-making and resource-management capacities of distributed intelligent agents.

### 4.4. Dynamic resource allocation

Utilize adaptive modulation techniques and dynamic resource allocation algorithms to optimize resource utilization based on user requirements and network conditions. This strategy improves the ability of the network to handle increasing demands and operate more effectively.

- MSC and GMSC: These are essential components of traditional cellular networks that utilize GSM technology. Present them as the essential points of our design, which may be located in the control plane layer.
- BSC and BTS: The Base Station Controller (BSC) and the Base Transceiver Station (BTS) are crucial elements of GSM networks. They are responsible for managing radio resources and facilitating connections with mobile devices.
- PSTN: The Public Switched Telephone Network (PSTN) is the traditional telephone network that handles circuit-switched voice communication.
- Placement: We affixed the MSC symbol onto the control plane of the diagram.
- Network Infrastructure Devices:
  - Switches: In the context of network infrastructure, the user and control planes play a vital role in establishing connections between devices.



- Routers: Routers are crucial for facilitating data routing and interconnecting different networks.
- Firewalls: Firewalls are crucial for maintaining network security by restricting access to unauthorized users and thwarting malicious activities.
- Load Balancers: Load balancers distribute incoming network traffic among multiple servers or resources to optimize resource utilization and ensure high availability.
- Management and Monitoring Systems:
  - Network Management Systems (NMS): To achieve centralized network management and monitoring, we established connections between switches and routers, and positioned them on the control plane.
  - Security Information and Event Management (SIEM) Systems: To achieve centralized network management and monitoring, we established links between the devices, switches, and routers, and placed them on the control plane.

#### **4.5. Simplified communication protocols**

Reduce intricacy and delay by incorporating streamlined protocols for communication between the control and user planes. This strategy considers the complexity of unconnected architectures. Efficient control-user plane communication methods were adopted to reduce intricacy and latency. This strategy addresses the increased intricacy of unconnected architectures. FTP, DNS, POP, HTTPS, BGP, SNMP, NETCONF, SOFP, IPsec, and SSL/TLS are all network protocols used for various purposes. FTP is used for file transfer, DNS is used for domain name resolution, POP is used for email retrieval, HTTPS is a secure version of HTTP for web communication, BGP is used for routing between autonomous systems, SNMP is used for network management, NETCONF is used for network configuration, SOFP is used for service orchestration and virtualization, IPsec is used for securing internet communications, and SSL/TLS is used for secure socket layer and transport layer security. Additionally, there are authentication mechanisms such as RADIUS and TACACS+ for user authentication, service orchestration protocols like REST API and NETCONF for managing services, and virtualization technologies like NFV and SDN for network virtualization.

#### **4.6. Advanced synchronization mechanisms**

Achieve accurate temporal synchronization between entities in the control plane and those in the user plane by employing sophisticated synchronization techniques. This solution alleviates the challenges related to synchronization in disconnected architectures.

- Clock Synchronization: To preserve precise timestamps across all network-connected systems and devices, we can utilize protocols such as the Network Time Protocol (NTP) or the Precision Time Protocol (PTP).
- Data Replication: Utilize data replication techniques to duplicate data across various locations or nodes inside the network.
- Consensus Algorithms: To achieve consensus across distributed nodes regarding

the state of shared data or the order of processes, it is advisable to employ a consensus mechanism such as Raft or Paxos.

- Transaction Management: Utilize distributed transaction management solutions to ensure that transactions in distributed systems demonstrate the ACID properties: atomicity, consistency, isolation, and durability.
- Conflict Resolution: Concurrency issues may arise when many nodes attempt to update shared data simultaneously. To address these issues, it is necessary to provide conflict resolution techniques.
- Quorum-based Systems: Create quorum-based systems where a decision or operation is considered valid only if a specific minimum number of nodes reach a consensus on it.
- Distributed locking: Facilitate the utilization of shared resources and prevent concurrent access by other nodes through the implementation of distributed locking mechanisms.
- Eventual Consistency: Distributed systems that do not require immediate consistency and can handle eventual convergence of data consistency should utilize eventual consistency models.

## 5. Implementation and results

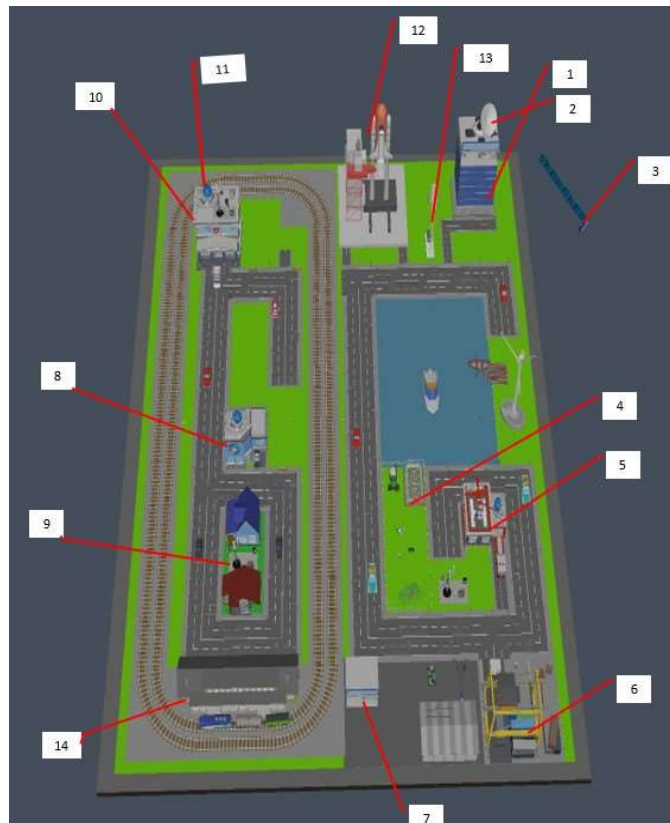

**Figure 5.** Proposed architecture based on 3D modeling App.

This section showcases a 3D model of the program (3D modeling App), which incorporates a sixth-generation network-integrated metropolis that has far-reaching impacts in fields as diverse as agriculture, industry, health, space exploration, and more, as shown in **Figure 5**. Important items are included in the form:

- **Company Headquarters:** There are numerous components to the corporate headquarters, the most crucial of which are servers and artificial intelligence.
- **Signal receiving dish:** To receive broadcast signals from satellites, like satellite TV or the Internet, one needs a satellite dish. To direct signal reception to the right satellite, a dish—typically a spherical metal disk—is placed on a building’s roof or in an open area. A reception enhancer built into the dish directs the signal to the internal receiver, which then transforms it into a form that the TV or other device can interpret. The user selects the suitable receiving dish according to his requirements and location from among several varieties that vary in size and characteristics.
- **Satellite Starlink:** With the use of sixth-generation networks’ cutting-edge wireless communication technology, the Starlink satellite can be linked to them. Communication satellites oversee the Starlink satellite network, and 6G technologies like smart grid and intelligent resource control can improve the efficiency and reliability of those connections. Improved service quality, faster connections, less transmission delay, a better user experience, and better service performance may all be achieved with 6G technologies such as power-optimized networks, broadband, and low latency.
- **Smart farm:** Smart technologies, like remote sensing and artificial intelligence, can boost agricultural output and product quality, allowing the sector to contribute to broader technological advancements.
- **Firefighting operations:** Firefighting operations could be enhanced using sixth-generation technology, which offers better communications, analyses data with artificial intelligence, and uses smart devices to track environmental conditions. This would make fire brigades’ reaction time and handling of fires more efficient.
- **Machine Control:** There will likely be significant advancements in the realms of communications and information technology brought about by 6G technology. With its lightning-fast, attack-proof wireless connections and incredibly tiny reaction times, this technology can help advance machinery control systems. For better and more precise machine management in agriculture or any other sector, this can aid in the creation of intelligent control systems.
- **Storage Management:** Residency for an information storage firm Space allocation, data, fast access, backup, and security activities are all part of efficient computer data storage management.
- **Police station:** By utilizing data analysis, artificial intelligence, smart devices, and sensor technology, sixth-generation technology can improve police capabilities through improved coordination and response to emergencies and crimes, as well as increased societal security and protection.
- **BSC Base Transceiver Station:** A Base Transceiver Station (BTS) is an essential component of wireless networks that facilitates wireless communication with mobile devices. The base station hardware (BTS) of a cellular network consists of the antennas and radio transceivers that allow mobile devices to communicate with the network. There is no precise notion of a “Base Transceiver Station” in 6G because of the growth of infrastructure and new technologies, which are expected to replace the BTS.
- **The hospital:** By facilitating remote treatment, data analysis, digital health apps,

sophisticated communications, and artificial intelligence, sixth-generation technology has the potential to enhance healthcare by making it more accessible and of higher quality.

- AI artificial intelligence: It is believed that 6G technology will heavily rely on artificial intelligence. Improved resource allocation, enhanced network performance, and enhanced adaptability to changing environments are all possible outcomes of incorporating AI into 6G networks. Optimization of energy usage, improvement of security, and effective network management are just a few examples of how AI may enhance the user experience and provide better personalised services.
- Space station: Improved communications, streamlined operations with data analysis and AI, and smart device and sensor technology for better space environment monitoring are just a few ways that space stations can reap the benefits of sixth-generation technology.
- BSC Base Station Controller: An element of a cellular network’s resource management system that oversees communications between base stations and the network’s central control center is referred to as a Base Station Controller in 6G networks.
- Train stations: Train passengers will enjoy better onboard connectivity thanks to the sixth-generation (6G) network’s increased coverage, faster data transfer rates, and cutting-edge applications like virtual and augmented reality.

**Figure 6** describes each component used on the 3D modeling App.



**Figure 6.** The component used in the 3D modeling App.

### 5.1. Results

- Vision and Requirements of 6G Wireless Systems: Based on our findings, the telecoms industry is in agreement about the lofty goals and demanding specifications of 6G wireless networks. All sorts of communication types, from

holographic to terahertz (THz) to massive machine-type communication (mMTC), are encompassed by these standards. To imagine the features and capabilities of future 6G networks, it is essential to understand these needs.

- **Challenges and Opportunities:** The results of our investigation have revealed a diverse array of potential opportunities and risks that constitute the environment of 6G wireless technologies. Major impediments to the implementation of 6G networks encompass challenges related to energy efficiency, security, privacy, interoperability, and the limited availability of spectrum. However, these challenges also present promising prospects for advancements in areas such as edge computing, distributed intelligence, AI-powered network optimization, and dynamic spectrum sharing.
- **Advanced Technologies and Architectural Components:** Our analysis focuses on the intricate interplay of advanced technology and architectural factors that will shape the future of 6G networks. Examples of these include quantum communication, virtualization, cloudnative architecture, decentralized protocols, massive MIMO (Multiple-Input Multiple-Output), millimeterwave communication, beamforming, and network slicing. The architects and engineers in charge of developing scalable and resilient 6G networks must possess a comprehensive understanding of these technologies.
- **Educational Framework for 6G Architecture:** Through our research, we have created an educational structure that will assist students in comprehending the intricacies of 6G architecture. This framework encompasses fundamental concepts, network protocols, system design principles, usage illustrations, and tangible realizations. Our architecture facilitates a comprehensive understanding of 6G wireless networks and empowers individuals to make significant contributions to the field's advancement by providing a clear roadmap for learners.
- **Implications and Contributions:** The field of telecommunications studies and education stands to benefit greatly from our endeavor. Students, teachers, and professionals can use it as a reference to learn everything there is to know about 6G wireless technologies. Our study also establishes a foundation for future research and practical applications that will bring the 6G network vision to fruition by outlining important results and creating an instructional framework.

**Foam Board:** The typical composition of foam board, a lightweight and long-lasting paper, is two layers of paper sandwiched together by a plastic foam core. Presentations, demonstrations, advertising, school projects, college projects, hobbies, and the fine arts are some of the most common uses. Cut out shapes and images from foam board and stick them on with glue or adhesive strips. It comes in a variety of colors and sizes (3 m, 5 m, 10 m) to suit the demands of different projects. The project makes use of a size of 3 m. **Figure 7** describes the novel proposed 6G architecture in a real environment.



**Figure 7.** Novel proposed 6G architecture in real environment.

## 5.2. Discussion

An improved, collaborative, real-time 3D modeling environment can be built using 6G's capabilities. Seamless real-time manipulation of complicated 3D models is now possible, even in collaborative contexts, thanks to 6G's ultra-low latency. Envision a scenario where numerous people can edit the same model in real time, with their changes being instantly visible to all. Super High Bandwidth: No lag whatsoever when streaming or manipulating massive, detailed 3D models with complex textures. Important fields that rely on this include engineering, virtual reality (VR) prototyping, and architectural design. Reducing reliance on centralized servers, edge computing brings processing power closer to the user at the network edge, allowing for faster rendering and manipulation of 3D models. Features like spatial awareness in a 3D modeling environment could be made possible by 6G's ability to integrate with AI. Picture AI-driven tools that analyze the model and its interactions with a virtual environment in real time and propose design enhancements based on that data. To make controlling 3D objects more immersive and tactile, advanced haptic feedback might be added. Sculpting and building design are two fields that might greatly benefit from this.

## 6. Conclusion and future work

6G architecture is a huge improvement over 5G, with the potential to support a broader array of devices and services, ultrareliable low-latency connectivity, and data rates in the terabit per second range. The network can be further transformed by integration with AI and maybe even with future technologies such as quantum computing. Even though there are still issues with security and standardization, ongoing research will lead to a 6G network that is both intelligent and pervasive, which

will have a profound impact on our daily lives. In this paper, we took the two architectures (decoupled RAN architecture and high-level architecture) from the 6G network, merged them, took the bad and good things, and produced a new architecture according to this research that is before you in the hope that the new architecture will work, and we made a model of an approximate imaginary city based on this architecture.

For 6G architecture, researchers are concentrating on the following areas: The sixth generation of wireless networks (6G) must support use cases that have not yet achieved widespread adoption. These include the Internet of Things (IoT) with its millions of linked devices and extremely immersive experiences (think ultra-realistic virtual reality). The network must be flexible enough to be divided into smaller parts to meet the specific needs of each application. Picture a slice with extremely low latency for essential infrastructure and another slice for regular usage. Integration of AI and ML: AI can automate network administration, optimize the allocation of resources, and even anticipate and avoid problems. 6G envisions a world where networked gadgets are everywhere and connectivity is seamless and ubiquitous. Because of this, reliable architecture is required to manage enormous data loads and provide smooth handoffs across various network types (e.g., terrestrial, satellite, etc.). With an ever-increasing attack surface, security must take precedence over sustainability. Another important consideration is power efficiency; 6G should be engineered to use less electricity.

**Author contributions:** Conceptualization, MAAS; methodology, MMAP; software, HAAJ; validation, AAKAK and JDAM; formal analysis, investigation, HAAJ; resources, AAKAK; data curation, MMAP and AAKAK; writing—original draft preparation, MMAP; writing—review and editing, MAAS; visualization, HAAJ and MMAP; supervision, MAAS; project administration, MMAP; funding acquisition, MAAS. All authors have read and agreed to the published version of the manuscript.

**Conflict of interest:** The authors declare no conflict of interest.

## References

1. Wang CX, You X, Gao X, et al. On the Road to 6G: Visions, Requirements, Key Technologies, and Testbeds. *IEEE Communications Surveys & Tutorials*. 2023; 25(2): 905-974. doi: 10.1109/comst.2023.3249835
2. Al-Shareeda MA, Manickam S. A Systematic Literature Review on Security of Vehicular Ad-Hoc Network (VANET) Based on VEINS Framework. *IEEE Access*. 2023; 11: 46218-46228. doi: 10.1109/access.2023.3274774
3. Kulkani NP, Mantri DS, Prasad NR, et al. 6G Future Vision: Requirements, Design Issues and Applications. In: Prasad R, Prasad AR, Mihovska A, Nidhi (editors). *6G Enabling Technologies*. River Publishers; 2022. pp. 23-43. doi: 10.1201/9781003360889-2
4. Al-Shareeda MA, Manickam S. MSR-DoS: Modular Square Root-Based Scheme to Resist Denial of Service (DoS) Attacks in 5G-Enabled Vehicular Networks. *IEEE Access*. 2022; 10: 120606-120615. doi: 10.1109/access.2022.3222488
5. Corici MI, Eichhorn F, Bless R, et al. Organic 6G Networks: Vision, Requirements, and Research Approaches. *IEEE Access*. 2023; 11: 70698-70715. doi: 10.1109/access.2023.3293055
6. A. Al-shareeda M, Anbar M, A. Alazzawi M, Manickam S, H. Hasbullah I. Security schemes based on conditional privacy-preserving vehicular ad hoc networks. *Indonesian Journal of Electrical Engineering and Computer Science*. 2021; 21(1): 479. doi: 10.11591/ijeeecs.v21.i1.pp479-488
7. Chowdhury MZ, Shahjalal Md, Ahmed S, et al. 6G Wireless Communication Systems: Applications, Requirements,

- Technologies, Challenges, and Research Directions. *IEEE Open Journal of the Communications Society*. 2020; 1: 957-975. doi: 10.1109/ojcoms.2020.3010270
8. Latva-Aho M, Leppanen K. Key drivers and research challenges for 6g ubiquitous wireless intelligence (white paper): 6G Flagship. University of Oulu; 2019.
  9. Tariq F, Khandaker MRA, Wong KK, et al. A Speculative Study on 6G. *IEEE Wireless Communications*. 2020; 27(4): 118-125. doi: 10.1109/mwc.001.1900488
  10. Al-Mekhlafi ZG, Al-Shareeda MA, Manickam S, et al. Chebyshev Polynomial-Based Fog Computing Scheme Supporting Pseudonym Revocation for 5G-Enabled Vehicular Networks. *Electronics*. 2023; 12(4): 872. doi: 10.3390/electronics12040872
  11. Huang T, Yang W, Wu J, et al. A Survey on Green 6G Network: Architecture and Technologies. *IEEE Access*. 2019; 7: 175758-175768. doi: 10.1109/access.2019.2957648
  12. Almazroi AA, Alqarni MA, Al-Shareeda MA, et al. FCA-VBN: Fog computing-based authentication scheme for 5G-assisted vehicular blockchain network. *Internet of Things*. 2024; 25: 101096. doi: 10.1016/j.iot.2024.101096
  13. Mohammed BA, Al-Shareeda MA, Alsadhan AA, et al. Efficient Blockchain-Based Pseudonym Authentication Scheme Supporting Revocation for 5G-Assisted Vehicular Fog Computing. *IEEE Access*. 2024; 12: 33089-33099. doi: 10.1109/access.2024.3372390
  14. Almazroi AA, Alkinani MH, Al-Shareeda MA, et al. FC-LSR: Fog Computing-Based Lightweight Sybil Resistant Scheme in 5G-Enabled Vehicular Networks. *IEEE Access*. 2024; 12: 30101-30112. doi: 10.1109/access.2024.3368393
  15. Khanh QV, Chehri A, Quy NM, et al. Innovative trends in the 6g era: A comprehensive survey of architecture, applications, technologies, and challenges. *IEEE Access*. 2023; 11: 39824-39844. doi: 10.1109/ACCESS.2023.3269297.
  16. Banafaa M, Shayea I, Din J, et al. 6G Mobile Communication Technology: Requirements, Targets, Applications, Challenges, Advantages, and Opportunities. *Alexandria Engineering Journal*. 2023; 64: 245-274. doi: 10.1016/j.aej.2022.08.017
  17. Lu Y, Ning X. A vision of 6G – 5G’s successor. *Journal of Management Analytics*. 2020; 7(3): 301-320. doi: 10.1080/23270012.2020.1802622
  18. Bhandari N, Devra S, & Singh K. Evolution of cellular network: from 1g to 5g. *International journal of engineering and techniques*. 2017; 3(5): 98-105.
  19. Zhang J, Stojmenovic I. Cellular networks. Available online: <https://citeseerx.ist.psu.edu/document?repid=rep1&type=pdf&doi=a6e3a4ff93c0a4011da52284264b6d1fedbe60b4> (accessed on 12 January 2024).
  20. Markoulidakis JG, Lyberopoulos GL, & Anagnostou ME. Traffic model for third generation cellular mobile telecommunication systems. *Wireless Networks*. 1998; 4: 389-400. <https://doi.org/10.1023/A:1019181028954>
  21. Mishra AR (editor). *Advanced Cellular Network Planning and Optimisation*. John Wiley & Sons; 2006. doi: 10.1002/9780470057629
  22. Morselli F, Modarres Razavi S, Win MZ, et al. Soft Information-Based Localization for 5G Networks and Beyond. *IEEE Transactions on Wireless Communications*. 2023; 22(12): 9923-9938. doi: 10.1109/twc.2023.3275122
  23. Kazmi SHA, Hassan R, Qamar F, et al. Security Concepts in Emerging 6G Communication: Threats, Countermeasures, Authentication Techniques and Research Directions. *Symmetry*. 2023; 15(6): 1147. doi: 10.3390/sym15061147
  24. Ahamed MM, Faruque S. 5G Network Coverage Planning and Analysis of the Deployment Challenges. *Sensors*. 2021; 21(19): 6608. doi: 10.3390/s21196608
  25. You X, Wang CX, Huang J, et al. Towards 6G wireless communication networks: vision, enabling technologies, and new paradigm shifts. *Science China Information Sciences*. 2020; 64(1). doi: 10.1007/s11432-020-2955-6
  26. Huang X, Zhang JA, Liu RP, et al. Airplane-Aided Integrated Networking for 6G Wireless: Will It Work? *IEEE Vehicular Technology Magazine*. 2019; 14(3): 84-91. doi: 10.1109/mvt.2019.2921244
  27. 3gpp commits to develop 6g specifications. Available online: <https://www.3gpp.org/news-events/3gpp-news/partner-pr-6g>. (accessed on 24 March 2024).
  28. 6G summit. Available online: <https://www.3gpp.org/technologies/6g-summit>. (accessed on 24 March 2024).
  29. Yu Q, Zhou H, Chen J, et al. A Fully-Decoupled RAN Architecture for 6G Inspired by Neurotransmission. *Journal of Communications and Information Networks*. 2019; 4(4): 15-23. doi: 10.23919/jcin.2019.9005430
  30. Tataria H, Shafi M, Molisch AF, et al. 6G Wireless Systems: Vision, Requirements, Challenges, Insights, and Opportunities. *Proceedings of the IEEE*. 2021; 109(7): 1166-1199. doi: 10.1109/jproc.2021.3061701